



SOUTHERN YELLOW PINE DECKS



BEAUTIFUL—DURABLE—RENEWABLE

AmericanSoftwoods.com

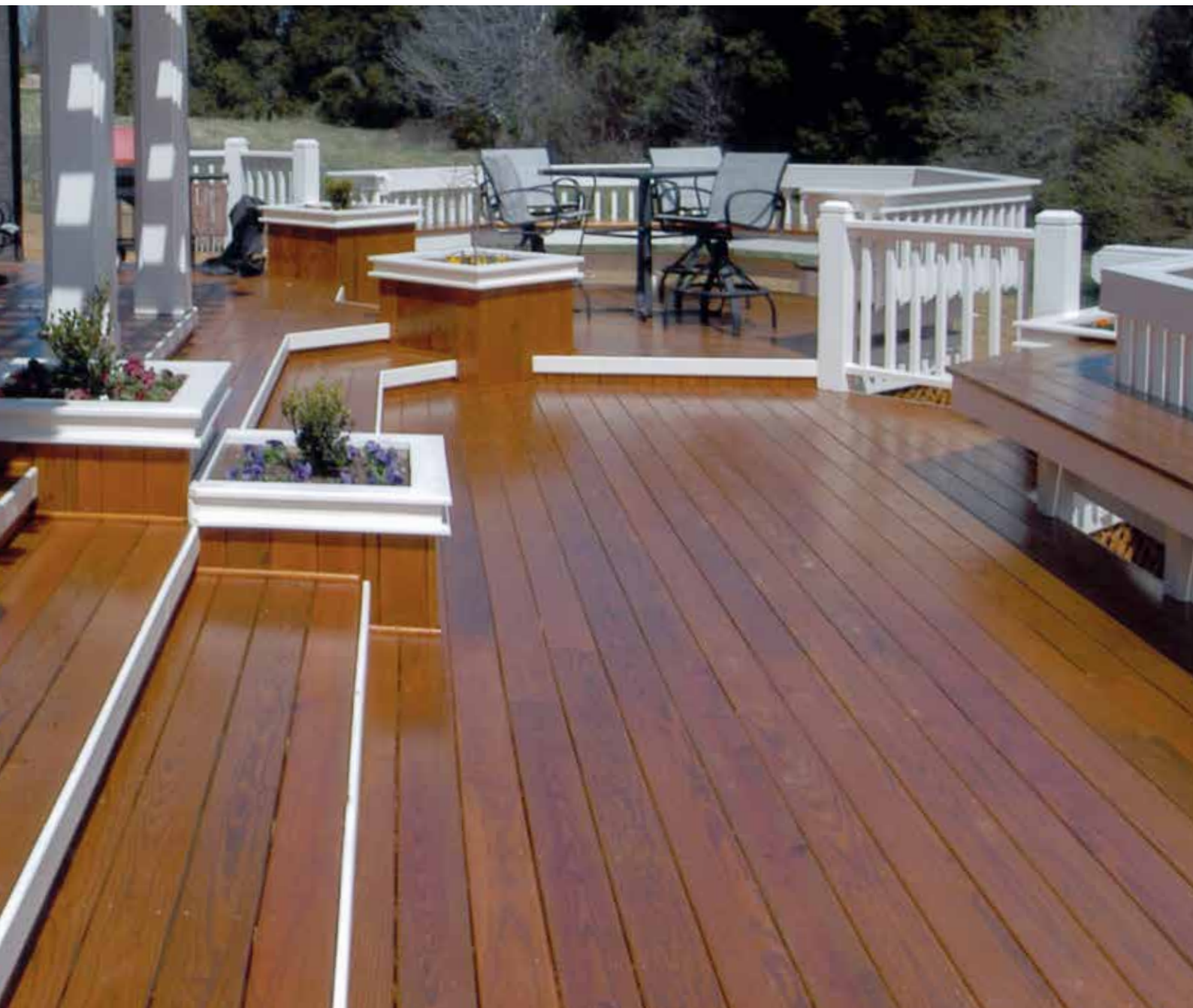

CONTENTS

- 2 Quality
- 3 Safety first
- 4 Design considerations
- 5 Choosing your decking
- 6-7 Building a deck
- 8-9 Getting the structure right
- 10 Weathering and surface finishes
- 11 The Green choice



QUALITY

Naturally good-looking, durable, easy to construct and environmentally-friendly, there's nothing like a timber deck to extend your living space outdoors. Southern Yellow Pine, the most popular choice for decking in America, is the natural choice in Europe too, where plentiful supplies of this beautiful, pressure-treated, certified timber are available.

Exposed to the elements, decks are external structural floors that must be able to support the loads placed on them for many years. Careful material selection, good design and installation practice, together with periodic maintenance, will ensure a timber deck provides a long and safe service life.

Quality

All Southern Yellow Pine decking components are manufactured in accordance with an independent, national quality scheme. This scheme not only ensures that the components themselves are manufactured consistently but that the level of preservative protection given to the component is appropriate to its end use. For example, posts to be embedded in the ground need a higher level of preservative protection than components such as deck boards that are out of ground contact. Under the Southern Yellow Pine quality scheme, every component must be either ink stamped or labelled to identify its quality and source. These marks are your reassurance that you are buying a quality material that is fit for purpose.



SAFETY FIRST



As with other construction materials, always put safety first when working with any kind of wood – treated or untreated. Avoid prolonged inhalation of sawdust. Use a dust mask and eye protection when sawing, sanding or machining wood. Wear gloves. After working with wood, wash exposed areas of skin thoroughly. Wash work garments separately from other clothing before reuse.

Treated wood should not be burned on open fires, in wood-burning stoves, fireplaces or residential boilers. Never use treated wood on barbecues. Dispose of off-cuts responsibly at your local authority's recycling facility.

Inspect your deck periodically

Inspect the condition of the deck surface, structural connections and balustrade railings at least once a year. Wood is a natural material and seasonal wetting and drying can cause fixings to loosen. Tighten any loose fixing and hammer home any nail heads that may have started to protrude.

Preservatives

Southern Yellow Pine is particularly suitable for pressure treatment, providing predictable long-term durability and resistance to decay and insect attack. The latest generation of preservatives is approved for use by government agencies in the USA, UK and all major wood-using markets worldwide as safe for use in every construction environment, including contact with people, plants and pets. For more information please refer to Pressure-Treated Southern Yellow Pine at www.SouthernPineGlobal.com/publications

Typical quality marks for treated timber (plastic and stamp or ink stamp)

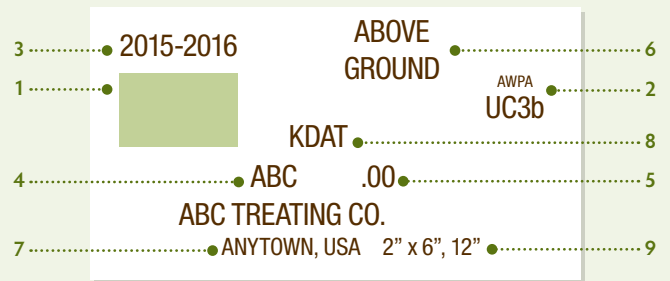
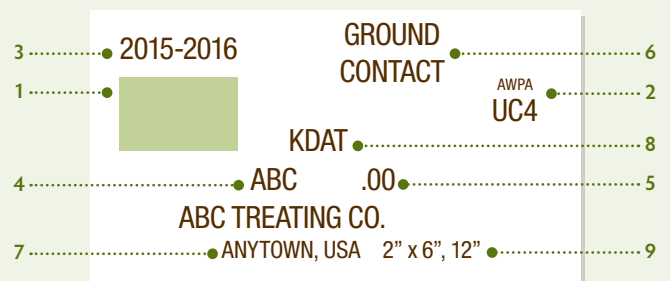

1. ALSC inspection agency mark
2. AWPAs Use Category
3. Year of treatment, if required
4. Preservative used for treatment
5. Preservative retention
6. Exposure category
7. Treating company and location
8. DRY or KDAT (Kiln-dried after treatment), if applicable
9. Length and/or class

Tip:

Make sure the wood is suitably treated for its intended exposure. Check plastic end tags or ink stamps for 'above ground' or 'ground contact'.

DESIGN CONSIDERATIONS

The location and design of a deck can be influenced by several factors:

- How it will be used (for sunbathing, large parties, family relaxation, outdoor cooking)
- How it relates to the existing structure (compatibility with function, environment, style)
- Sunlight (sun or shade)
- Privacy (screen certain areas, avoid street noise, landscaping)
- Terrain (elevated deck, ground level, split level)
- Access to and from the home (adjoining kitchen, dining room, living room or bedroom)

Once the basic size, shape and location of the deck are determined, check with your Local Authority to find out if planning or building control consent is required prior to work commencing. Local Authority requirements may vary from one region to another so it's advisable not to purchase any materials or start work until you know that your deck is permitted.

It's important to locate the deck so as to avoid obstructing access to any buried electricity cables or manhole covers. If in doubt, contact utility providers before any digging begins to determine the exact location of buried cables or pipes to which access may be required in the future. Create a hatch in the deck to permit access to manhole covers if necessary.



Tip:

Where board ends abut one another, install an additional length of joist (measuring at least the width of three boards) to provide adequate support for fixings.



Photo © Manchester Deck Co.

CHOOSING YOUR DECKING

Southern Yellow Pine decking is produced in a variety of profiles and grades, along with water-repellent and kiln-dried after treatment (KDAT) options. See Table 1. Please note that Southern Yellow Pine decking components are manufactured in Imperial sizes only. Conversions to metric dimensions should be considered as approximate only.

Use the right preservative treatment

Make sure the wood is treated for its intended exposure. Check plastic end tags or stamps fixed to the timber for 'above ground' or 'ground contact'. Do not use timber marked 'above ground' for ground contact applications.



Photo © Manchester Deck Co.

Table 1. Southern Yellow Pine decking selection guide¹

Decking option	Grade	Nominal size	Actual Size	Lengths	Water-repellent ⁴ Kiln-dried after treatment (KDAT) ⁴
Radius edge ²	Premium	32 x 152mm (5/4" x 6")	25 x 140mm (1" x 5 1/2")	2.4m (8')	Check supplier
	Standard			3.0m (10')	
Dimension	No.1	51 x 102mm (2" x 4")	38 x 89mm (1 1/2" x 3 1/2")	3.65m (12')	
	No.2	51 x 152mm (2" x 6")	38 x 140mm (1 1/2" x 5 1/2")	4.27m (14')	
Patio ³	Patio 1	32 x 152mm (5/4" x 6")	29 x 140mm (1 5/32" x 5 1/2")	4.87m (16')	
	Patio 2				

¹ Consult your timber supplier to source the specific Southern Yellow Pine components you require.

² Radius Edge Decking (R.E.D.) is typically manufactured 6mm (1/4") round on all four edges, but may be offered 6mm (1/4") round on the top two edges only.

³ Patio typically manufactured 10mm (3/8") round on all four edges.

⁴ Built-in water repellent and kiln drying options improve decking performance by minimizing defects caused by the natural expansion and shrinkage that wood experiences over the seasons.



Dimension 51 x 102mm (2" x 4")



Patio decking



Radius edge decking



Dimension 51 x 152mm (2" x 6")

Deck layout

Plan the layout of your deck carefully; planning saves time and money, reducing cutting and waste. For example, no cuts are required if the width of your deck is designed to match a typical decking board length (e.g. 8', 10', 12', 14', 16' – or roughly 2.4m, 3.0m, 3.65m, 4.27m, 4.87m).

Tip:

Where deck boards have visible growth rings in an arc pattern, lay the boards with the top of the arc uppermost, 'bark side up', to help reduce cupping.

BUILDING A DECK

A deck is made up of many components – foundations, posts, beams, bracing, joists, decking, wall plates/ledger boards, edge boards, newel posts, balustrades and stairs – all requiring proper connections.

There are two common methods for supporting a deck. One is to attach the deck directly to a property with a wall plate, sometimes referred to as a ledger board. The proper installation of this wall plate is critical, to avoid bridging damp courses. The alternative method is to construct a non-ledger deck adjacent to the house, supported on all corners by vertical posts. The joists of the deck should be at least 25mm (1") away from the brickwork damp course.

Ground-level decks

Site preparation is important for ground-level decks. Prepare an area approximately 300mm (2 ft) larger than the footprint of the proposed deck. Remove any vegetation, turf or soil to a depth of 600mm (2" or 3") and backfill with ballast, crushed limestone or gravel to prevent water from collecting beneath the deck. Be sure the excavated ground slopes slightly to direct any runoff away from the deck and home. To prevent weeds and unwanted vegetation from growing beneath the deck, spread perforated black garden paper or geotextile membrane over the area. Secure the sheeting in place with proprietary clips or with gravel. At the exposed edges, cover with gravel, pebbles, or other decorative edging such as bark.

Figure 1:
Deck supported
by a ledger attached
to the house

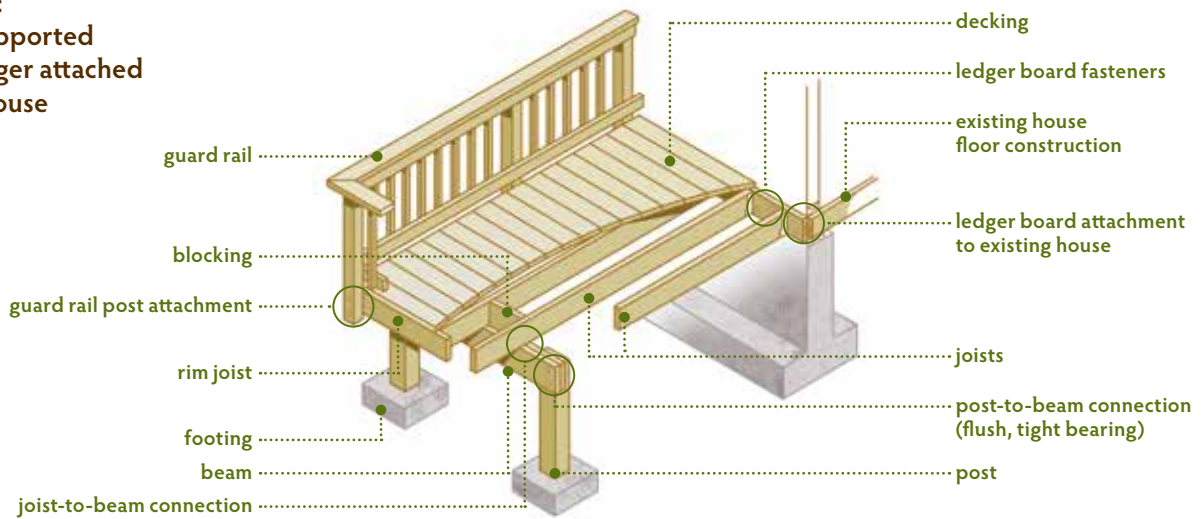
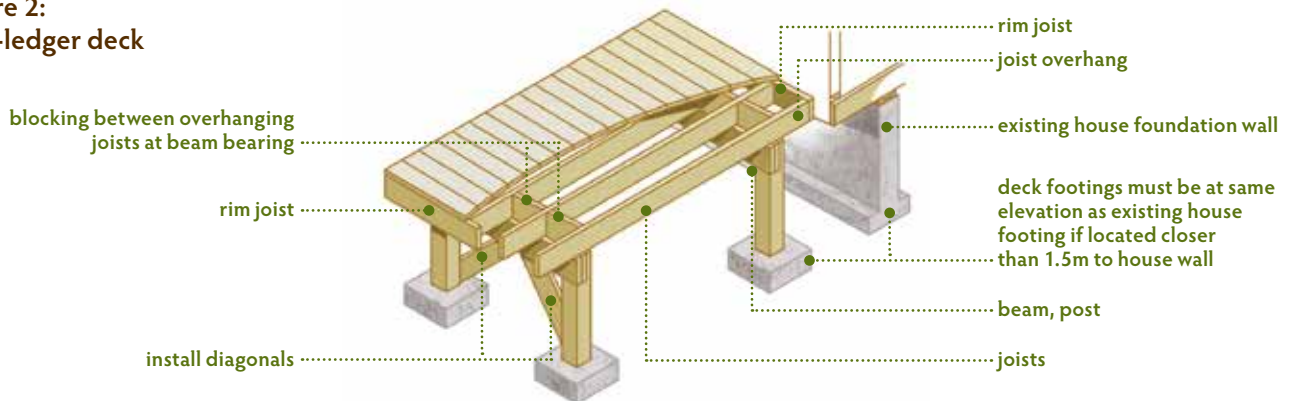

Figure 2:
Non-ledger deck





Posts

Posts for ground floor decks should be a minimum of 100mm x 100mm (4" x 4"). Posts for all other decks should be a minimum of 150mm x 150mm (6" x 6"). Use Southern Yellow Pine No.1 or No.2 grades in solid or laminated timber made from three sections of 50mm x 150mm (2" x 6"). The maximum installation height of posts is 3.65m (14') or the height of the first floor. For decks higher than 600mm (2') above the ground, diagonal bracing is recommended. Posts must be pressure-treated for ground contact use – check the grade stamps or end-tags for confirmation.

Support posts can be notched to accommodate a housing for the beam. However, this may expose untreated wood to decay if it is not re-treated on site. It also reduces the cross-section of the post, which may reduce its strength. To avoid notching, use a post cap metal connector to attach the beam directly to the top of the post. If high lateral loads are anticipated (e.g. wind), notching is not recommended.

Posts, and the foundations that secure them, transfer loads from the deck beam and framing to the ground and should be securely anchored to resist uplift in a strong wind. There are a number of ways posts may be secured. Details of deck posts that conform with UK practice can be found on The Timber Decking and Cladding Association (TDCA) website (www.tda.org.uk).

Ledger boards

When installing ledger boards (timber wall plates) on structural masonry walls, a minimum 15mm (½") gap should be allowed to permit water running down the wall to drain freely. The TDCA publishes details on fixing wall plates to structural walls. On timber frame properties, follow the recommendations for ledger board fixing given in the **Prescriptive Residential Wood Deck Construction Guide** (available at www.awc.org).

Connections

The proper selection and installation of decking fasteners is essential to long-term performance. The most common fixings are nails, screws or hidden fasteners. All hardware used with pressure treated wood in outdoor applications must be corrosion-resistant. Stainless steel or high performance coated fasteners are best. Hot-dipped galvanized fixings and connectors offer the minimum acceptable corrosion resistance. Do not use standard steel, brass, electro-plated or aluminium fixings and connectors. Always fix connectors using nails or screws made from the same metal to prevent galvanic corrosion. Much of the **Prescriptive Residential Wood Deck Construction Guide** is devoted to proper connection details and includes guidance for the following:

- Footing-to-post connections
- Post-to-beam connections
- Joist-to-beam connections
- Decking-to-joist connections
- Rim joist connections
- Bracing attachments
- Ledger board attachments
- Freestanding deck attachment to house
- Guard details and attachments
- Guard post attachments
- Stair details and attachment



Tip:

When attaching fixings near the ends of decking, pre-drill holes to help prevent splitting.

GETTING THE STRUCTURE RIGHT

Joists and beams

The span of a joist is measured from the centre of the post at one end of the joist to the centre of the post at the other end of the joist and does not include the length of any overhang. Use Table 2 to determine the joist span based on timber size and joist spacing. Refer to Table 3 for deck beam spans. Joists may rest on the beam and extend past the beam centre line up to $L_j/4$, or the joists may attach to the side of the beam using joist hangers. However, joists should not be attached to opposite sides of the same beam. Refer to the **Prescriptive Residential Wood Deck Construction Guide** for joist-to-beam connection details, plus beam assembly details where two or more members are used.

Spans

Southern Yellow Pine decking and 50 x 150mm (2" x 6") timber used for decking are both rated to span up to 600mm (24") between joist centres when installed perpendicular to the joist system (N.B. boards must span across at least three joists). However, limiting the joist centres to 400mm (16") reduces board deflection (bounce). When installing decking diagonally, always space joists at 400mm (16") centres.

Do not exceed maximum spans for structural deck components, such as joists and beams. Consult maximum span tables in the **Prescriptive Residential Wood Deck Construction Guide**.

Table 2. Southern Yellow Pine maximum joist spans (L_j)¹

Size	Joist Spacing (o.c.)					
	Allowable Span (L_j)			Allowable Overhang (L_o) ²		
	300mm (12")	400mm (16")	600mm (24")	300mm (12")	400mm (16")	600mm (24")
50 x 200mm (2"x 8")	3.99m (13' 1")	3.61m (11' 10")	2.95m (9' 8")	560mm (1' 10")	600mm (2' 0")	710mm (2' 4")
50 x 250mm (2"x 10")	4.93m (16' 2")	4.27m (14' 0")	3.48m (11' 5")	940mm (3' 1")	1.04m (3' 5")	864mm (2' 10")
50 x 300mm (2"x 12")	5.49m (18' 0") ³	4.88m (16' 6")	4.45m (13' 6")	1.37m (4' 6")	1.27m (4' 2")	1.02m (3' 4")

¹ Assumes 1.915 kN/m² live load, 0.479 kN/m² dead load, L/360 deflection, No. 2 grade and wet service conditions.

² Maximum allowable overhang cannot exceed L/4 or ¼ of actual main span. Assumes cantilever length/180 deflection with 100 kg point load.

³ Joist length prescriptively limited to 5.49 metres for footing design.

Table 3. Southern Yellow Pine deck beam spans (LB)¹

Size ²	Joist Spans (L_j) less than or equal to:						
	1.83m (6')	2.44m (8')	3.05m (10')	3.66m (12')	4.27m (14')	4.88m (16')	5.49m (18')
(2) 50 x 150mm (2"x 6")	2.03m (6' 8")	1.73m (5' 8")	1.55m (5' 1")	1.40m (4' 7")	1.30m (4' 3")	1.22m (4' 0")	1.14m (3' 9")
(2) 50 x 200mm (2"x 8")	2.59m (8' 6")	2.23m (7' 4")	1.98m (6' 6")	1.80m (5' 11")	1.68m (5' 6")	1.55m (5' 1")	1.45m (4' 9")
(2) 50 x 250mm (2"x 10")	3.07m (10' 1")	2.67m (8' 9")	2.36m (7' 9")	2.16m (7' 1")	1.98m (6' 6")	1.85m (6' 1")	1.75m (5' 9")
(2) 50 x 300mm (2"x 12")	3.63m (11' 11")	3.15m (10' 4")	2.79m (9' 2")	2.54m (8' 4")	2.36m (7' 9")	2.21m (7' 3")	2.06m (6' 9")
(3) 50 x 150mm (2"x 6")	2.41m (7' 11")	2.18m (7' 2")	1.96m (6' 5")	1.78m (5' 10")	1.65m (5' 5")	1.52m (5' 0")	1.45m (4' 9")
(3) 50 x 200mm (2"x 8")	3.23m (10' 7")	2.82m (9' 3")	2.51m (8' 3")	2.29m (7' 6")	2.11m (6' 11")	1.96m (6' 5")	1.85m (6' 1")
(3) 50 x 250mm (2"x 10")	3.89m (12' 9")	3.25m (11' 0")	2.97m (9' 9")	2.67m (8' 9")	2.51m (8' 3")	2.34m (7' 8")	2.21m (7' 3")
(3) 50 x 300mm (2"x 12")	4.57m (15' 0")	3.96m (13' 0")	3.53m (11' 7")	3.20m (10' 6")	2.97m (9' 9")	2.77m (9' 1")	2.62m (8' 7")

¹ Assumes 1.915 kN/m² live load, 0.479 kN/m² dead load, L/360 simple span beam deflection limit, L/180 cantilever deflection limit, No. 2 stress grade and wet service conditions. Deck beam spans (LB) can extend past the post centre line up to $LB/4$.

² Beam depth must be equal to, or greater than, the joist depth if joist hangers are used.



Photo © Manchester Deck Co.

Parapets and balustrade rails

Under UK building regulations, any deck platform more than 600mm (24") above ground level must have a safety parapet/guard rail at least 1100mm (43") in height. Newel posts must be a minimum of 100 x 100mm (4" x 4"). Guard rails fitted to stairs must include a graspable handrail on at least one side.

Parapets must include a balustrade infill that prevents the passage of a 100mm (4") sphere. The TDCA (www.tda.org.uk) publishes a guide to safety parapets where compliance with UK building regulations is required. If a deck is under 600mm high, balustrades are considered decorative and need only be 900mm high.

All safety parapets (newel posts, horizontal rails, balusters) should be installed as an independent system. Do not incorporate ground support posts as part of the guard rail system. Guard rail posts should be properly connected to the rim joist using bolts.

Spacing boards

The width of pressure-treated Southern Yellow Pine decking may vary due to moisture contact, so spacing between boards should be adjusted at installation to compensate for shrinkage as the wood dries.

Most Southern Yellow Pine deck boards have either been air or kiln-dried after treatment to a moisture content of 18%, plus or minus 2%. This is the ideal condition for laying at any time of year in the UK, minimizing potential defects caused by shrinkage. A gap should always be left between one deck board and another to help ventilate the under deck area, facilitate drainage and allow for any change of dimensions in the board as its moisture content increases and decreases with each season. A minimum of 5mm (¼") to a maximum of 10mm (¾") is recommended. Leave a gap of 5mm (¼") where a board end abuts a post.

Tip:

Upper ends of railing posts should be covered with caps or cut at an angle to shed water.



Photo © Manchester Deck Co.

WEATHERING AND SURFACE FINISHES

Horizontal deck surfaces are often directly exposed to sun and moisture, weathering rapidly. As repeated cycles of wetting and drying occur, surface checks (small cracks) can develop and exposed end-grain surfaces may begin to retain moisture.

With changes in its moisture content, wood used outdoors shrinks and swells continuously, subjecting any finishes to excessive stress. Although treated wood is protected against decay and insect attack, the application of a water-repellent sealer to all exposed surfaces is recommended when construction is complete. This sealer will help control surface checking (splitting or cracking) and help to maintain an attractive appearance. Over time, re-application of a sealer is recommended, perhaps every year or two.

Over several months, pressure-treated Southern Yellow Pine will weather naturally to an attractive silver-grey. Should you decide to paint or stain the treated material, you will find that it will accept a finish as readily as untreated Southern Yellow Pine. Most importantly, treated Southern Yellow Pine should be dry before any type of finish is applied.

Stain and paint manufacturers typically recommend a waiting period of between a week and two months from construction of a treated wood deck and applying a paint or stain. If the project was built with Southern Yellow Pine that was kiln-dried after treatment, the finish can be applied right away. When using paint, most manufacturers recommend two coats of an acrylic paint for best results on treated Southern Yellow Pine. Unless specifically manufactured for decking decoration, solid-colour stains should never be used on deck boards or stair treads as these will not withstand the wear of foot traffic.

For best results, always follow the manufacturer's application instructions.



Photo © Manchester Deck Co.

Maintenance

On weathered decks, the original colour of the wood can be restored (and surface mildew and mould removed) using a proprietary deck cleaner, brightener or restorer. If a pressure washer is used to clean a deck surface, care should be taken not to remove any of the wood itself.



Photo © Manchester Deck Co.

Tip:

The splash test

Regardless of a deck's age, when should you apply (or reapply) a finish? Here's the simple test:

First, be sure the wood surface is thoroughly dry. Splash water and observe its dispersion.

- A. Water droplets form on contact when:
1. for newly constructed decks, the timber is not yet sufficiently dry to accept a finish, OR
 2. for existing decks, the finish is performing satisfactorily.
- B. If droplets do not form and water is absorbed into the wood, it's time to apply or reapply a sealer or stain.



A. Finish is OK



B. Time to reapply

THE GREEN CHOICE

Wood products are the most environmentally responsible building material available. Naturally renewable, wood acts as a carbon store and comes from forests that act as carbon sinks. In the US, forests are

widely recognized as stable and well-managed. Today, they cover about the same area as a century ago, and the growing stock has actually increased by 11% from 74,913 million m³ in 1990 to 82,941 million m³ in 2010⁹

Wood products are the only major building products with a third-party certification system in place to verify their origination from sustainably managed resources.



Sustainable resources

Wood products are produced from trees, a naturally renewable resource. More wood is grown each year in the U.S. than is harvested.



Responsible manufacturing

Waste is virtually eliminated when trees are used to make wood products. Bark, trims and sawdust are used as an energy source to help power wood production facilities. It takes far less energy and fossil fuels to produce wood products than to manufacture concrete and steel.



Quality construction

As a building material, wood offers a unique combination of benefits, including strength, affordability, ease-of-use and environmental superiority.



Recycle, renew

At the end of their initial service life, wood products are easily recycled for other uses. Wood contributes fewer greenhouse gas emissions than recycled steel and concrete.

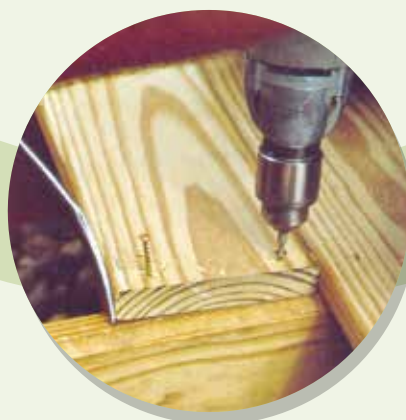

Renovation, upgrade

The flexibility of wood makes renovating a home easy and affordable. Wood is builder-friendly, as well as environmentally friendly. Wood also enhances the aesthetic value of a home when used as flooring, cabinetry, furniture and moulding.



Long service life

The durability of wood products contributes to the long life of a home. Wood products also store carbon, reducing the amount of carbon in the atmosphere.

⁹ Global Forest Resources Assessment, FAO, 2010



Copyright © 2018 Southern Forest Products Association. All rights reserved.

AmericanSoftwoods.com

Contact us

This brochure is published by American Softwoods, which exists to promote the quality and benefits of pressure-treated Southern Yellow Pine to markets worldwide. American Softwoods is a member of The Timber Decking and Cladding Association (TDCA), an organization established to promote quality decking materials and best practice in the UK.

A wide range of UK-specific information, ranging from compliance with Local Authority planning and building control requirements to the TDCA's Code of Practice, is available from www.tdca.org.uk A free PDF download of the American Wood Council's **Prescriptive Residential Wood Deck Construction Guide** is available at www.awc.org

Southern Forest Products Association's global representatives are ready to assist with product or technical information.

Find regional contacts at www.SouthernPineGlobal.com

Certified Southern Yellow Pine is widely available.
Visit www.SouthernPineGlobal.com/product-locator for suppliers.

The conditions under which timber is used in construction may vary widely, as does the quality of workmanship. Neither American Softwoods nor the organizations behind it have knowledge of the quality of workmanship or construction methods used on any construction project and, accordingly, do not warrant the design or performance of the timber in completed structures.

Southern Forest Products Association
6660 Riverside Drive, Suite 212
Metairie, LA 70003 USA

Tel: 001-501-443-4464
www.SouthernPineGlobal.com
Email: mail@sfpa.org

